

# INLINE HINGE PANEL SHOWER SERIES (technical drawings)

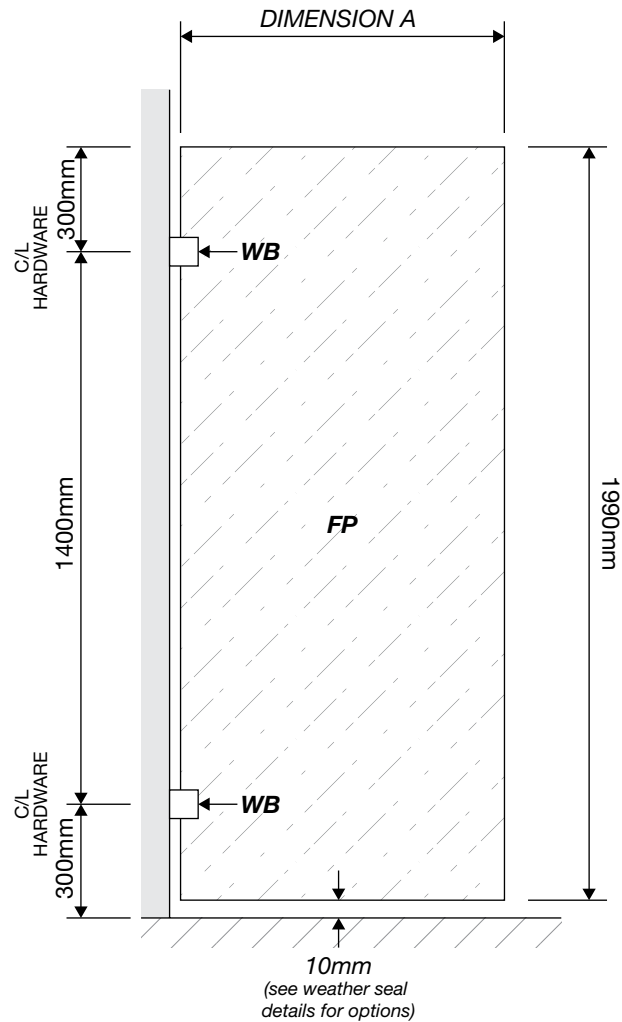

## LEGEND

<b>DIMENSION A</b>	The overall dimension including gaps between glass panels, NOT including gap between glass and wall ( $4\text{mm} \pm 1$ to gap recommended).
<b>FP</b>	Shower screen fixed glass panel (FP Glass Series).
<b>WB</b>	Wall Bracket x2
<b>K</b>	Knob x1

*\*\* All glass is 10mm clear toughened. \*\**

ELEVATION DRAWING

# INLINE FIXED PANEL SHOWER SERIES (technical drawings)

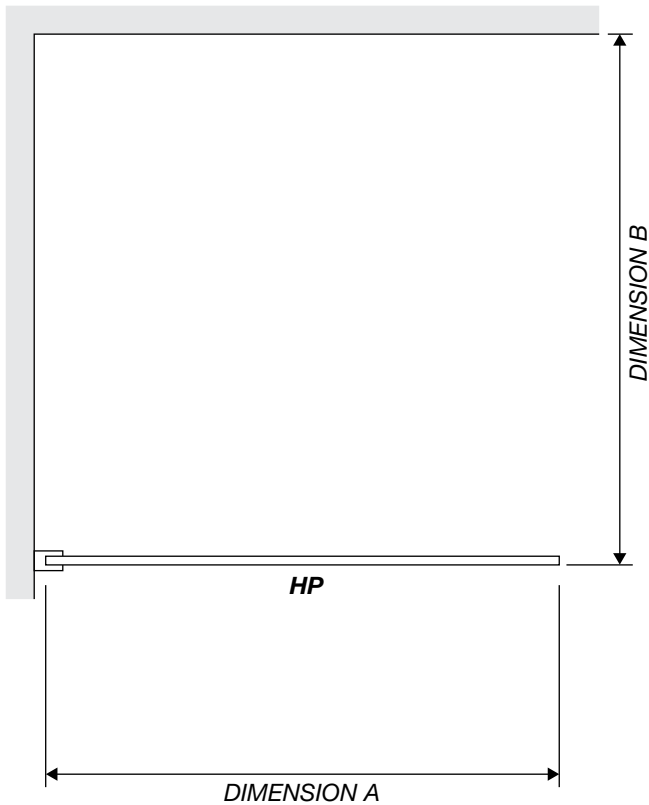

**Dimension A**, is the overall dimension including gaps between glass panels, NOT including gap between glass and wall (4mm $\pm$ 1 to gap recommended).

**Dimension B**, is the overall dimension NOT including the gaps between glass and wall (4mm  $\pm$ 1 gap is recommended).

Between fixed panel and wall, silicon beading is required.

# WALL/FLOOR MOUNTING APPLICATIONS

## 1/ CLAMP

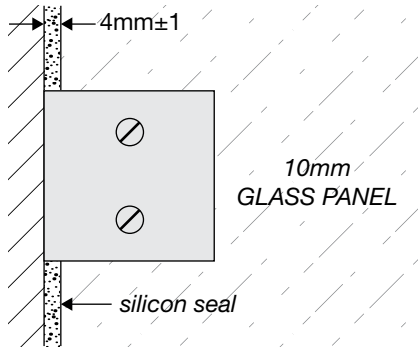

## 2/ CHANNEL

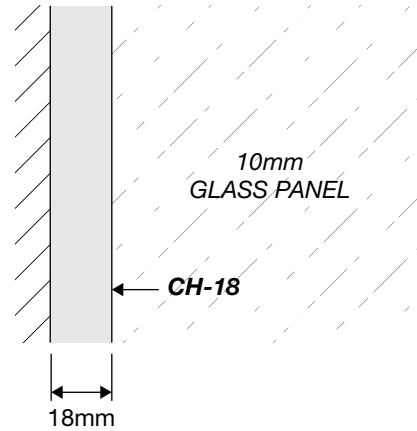

## 3/ REBATED CHANNEL (INTO TILES)

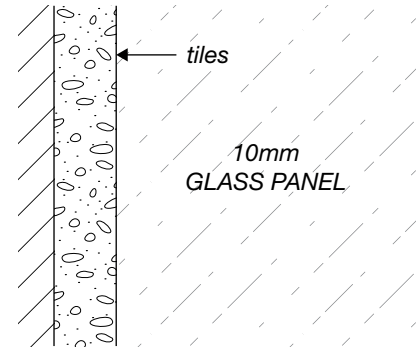

## 4/ GLASS-TO-FLOOR SEAL

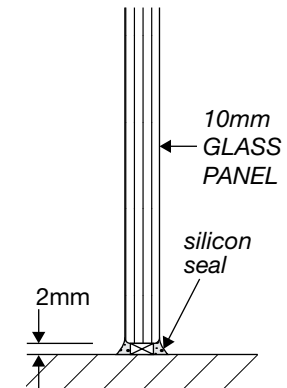
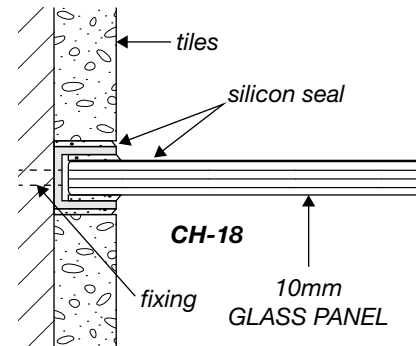
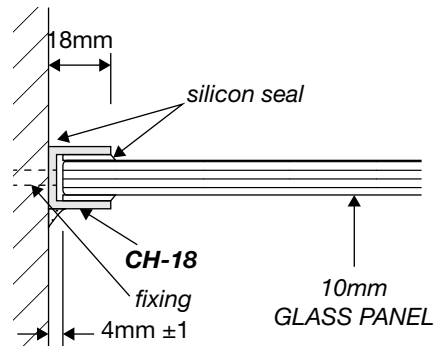
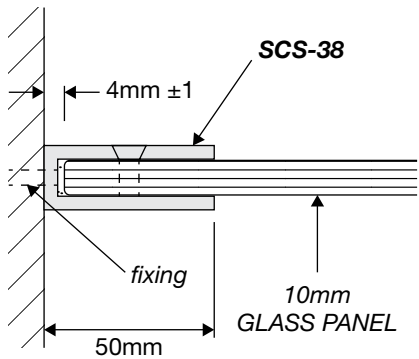
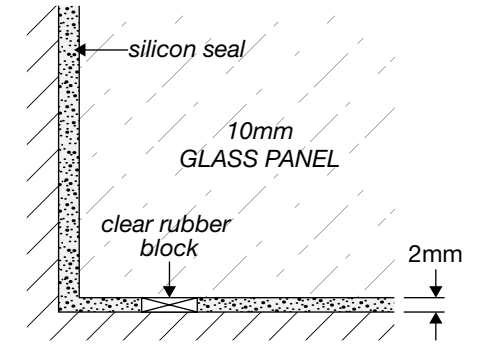

WALL MOUNT DRAWINGS

# CLEAR WATER SEAL APPLICATIONS

OPTION 1

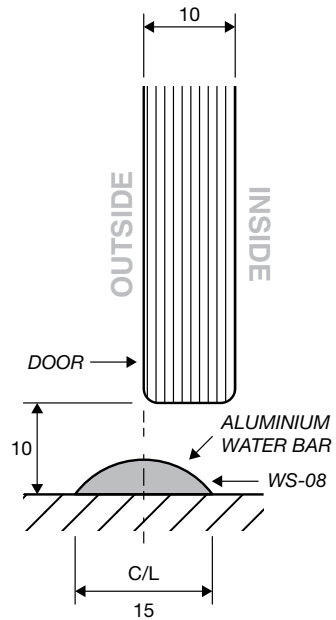

OPTION 2

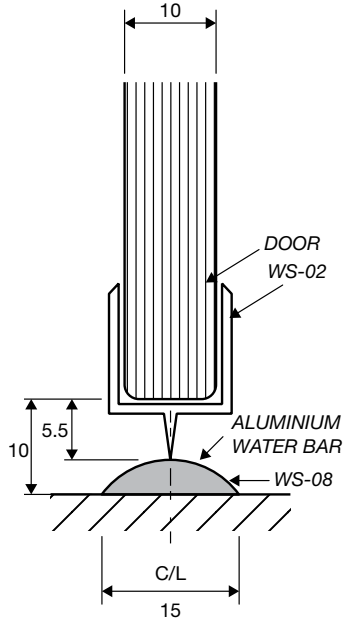

OPTION 3

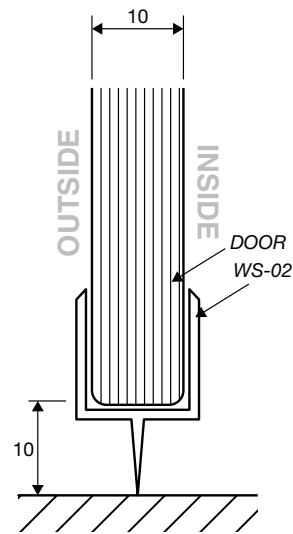

OPTION 4

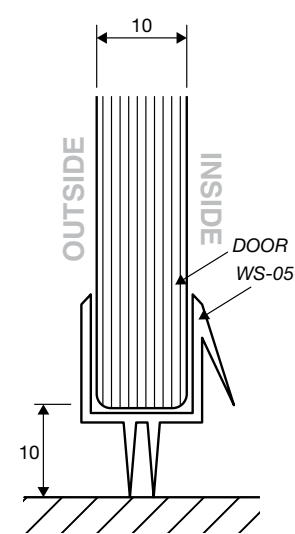

OPTION 5

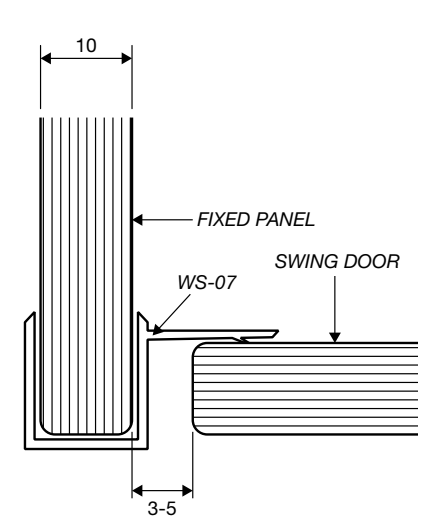

OPTION 6 (FLOOR TO FIXED PANEL SEAL)

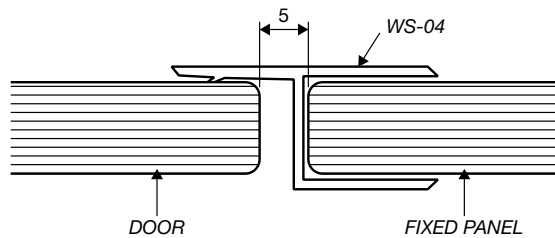

OPTION 7 (135° JOINT SEAL)

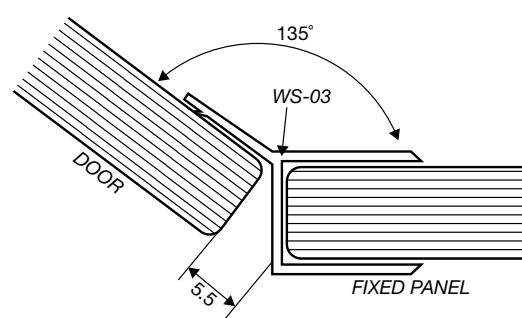

SEAL APPLICATION DRAWINGS