

INGROUND SERIES POOL FENCE DETAILS

LAYOUT

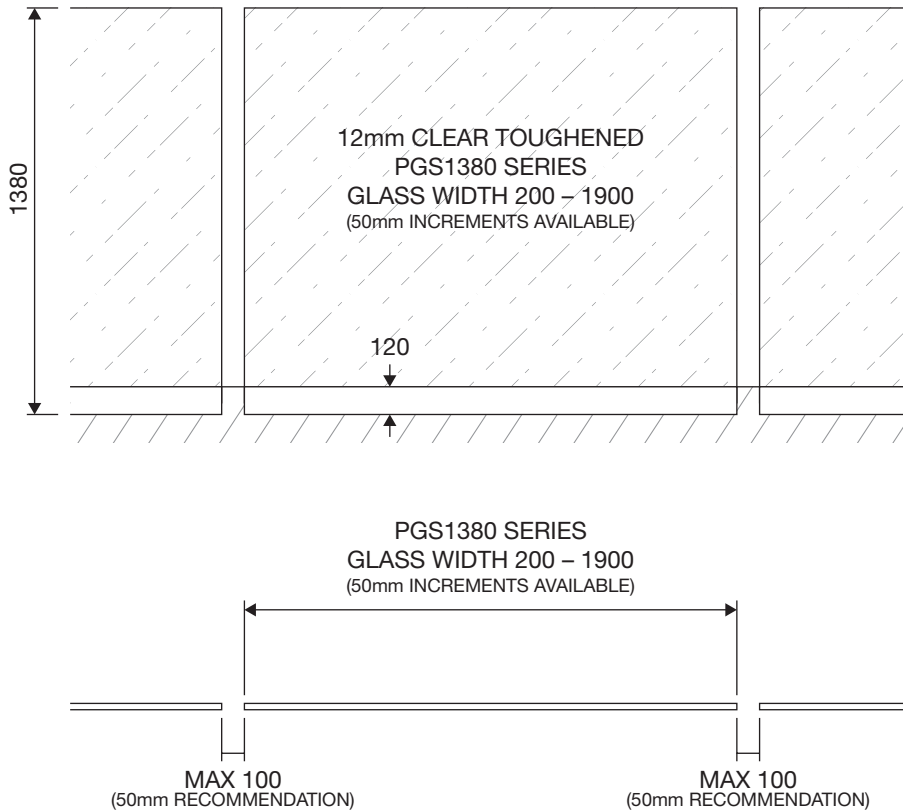

ASSEMBLY

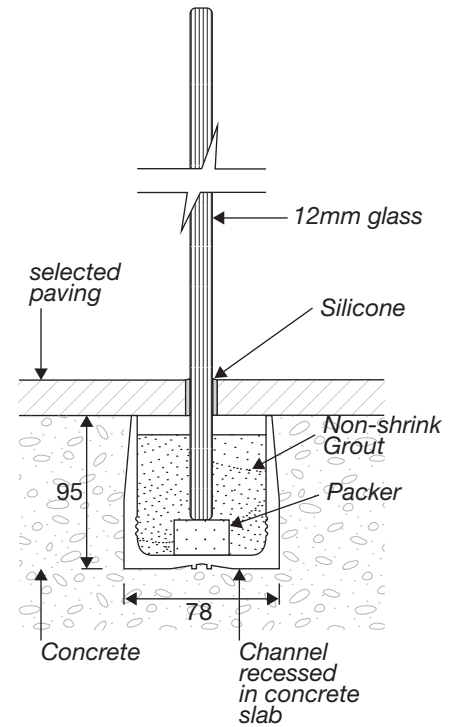

PRODUCT TYPE/

Stainless Steel + Pool Gate [IN-GROUND Series]

Pool fence application will be dependant on a number of factors including the environmental conditions and pool fence type. We recommend that you consult with a suitable qualified engineer to determine suitability on an individual project basis.

GATE PACKAGES TO SUIT/

- PGP/FS - Floor Spring Package
- PGP/MH - Magna Hinge Package
- PGP/MTH - Metro Hinge Package