

INLINE SLIDING SHOWER SERIES (technical drawings)

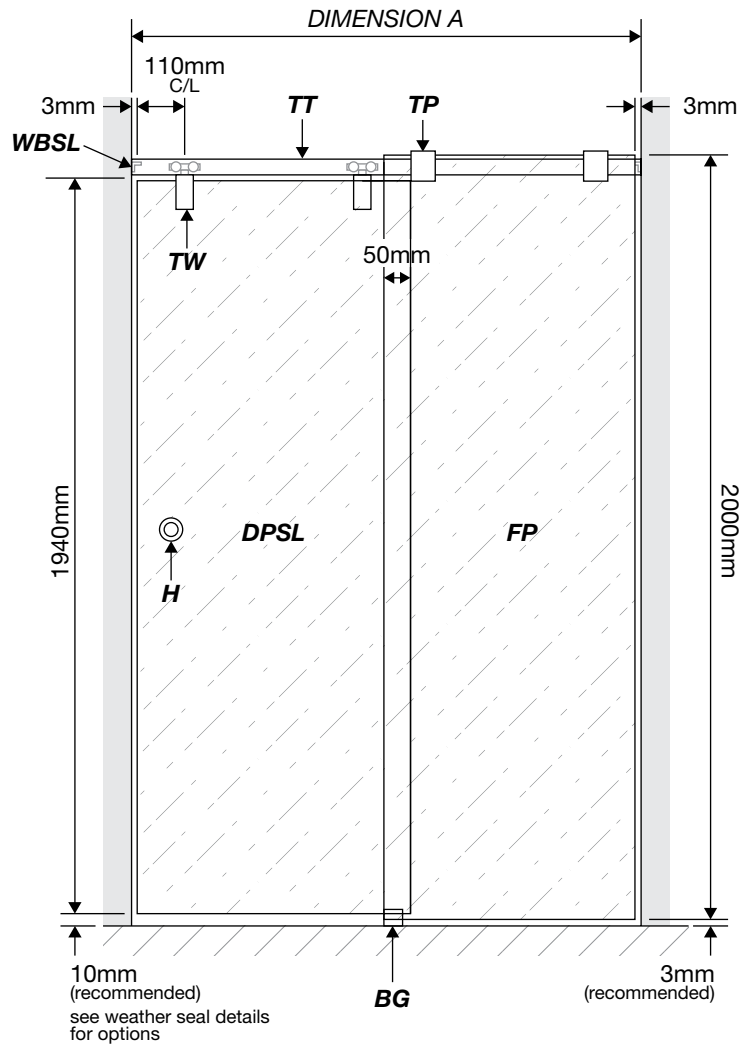

LEGEND

DIMENSION A	The overall dimension including gaps between wall and all glass panels.
FP	Shower screen fixed glass panel (FP Glass Series).
DPSL	Sliding shower screen door glass panel with hinge cutouts and hole for selected door knob.
TT	Top Track 2000mm x1 *to be cut to size of Dimension A
TP	Top Patch x2
WB	Wall Bracket x2 (inside Top Track)
BG	Bottom Guide x1
H	Hole Handle x1
TW	Track Wheels x2

**** All glass is 10mm clear toughened. ****

ELEVATION DRAWING

INLINE SLIDING SHOWER SERIES (technical drawings)

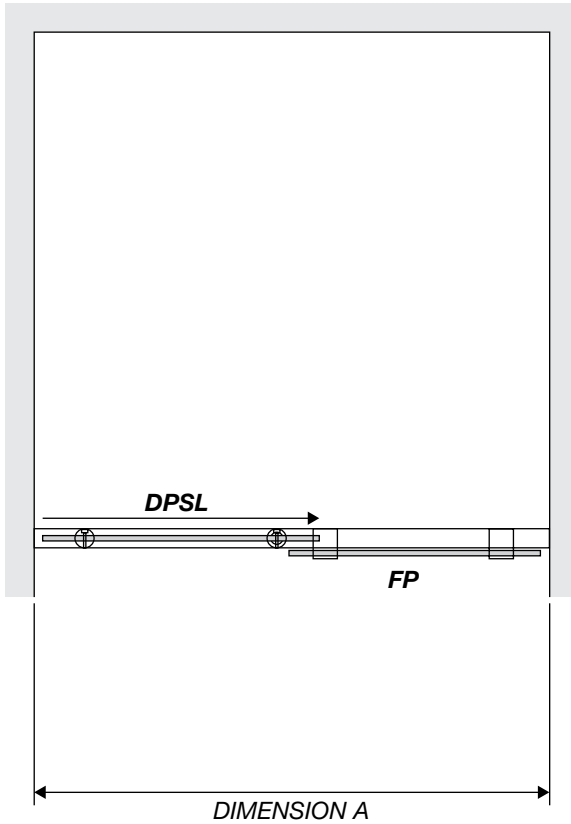

Dimension A, is the overall dimension including gaps between wall and all glass panels.

WALL/FLOOR MOUNTING APPLICATIONS

1/ CLAMP

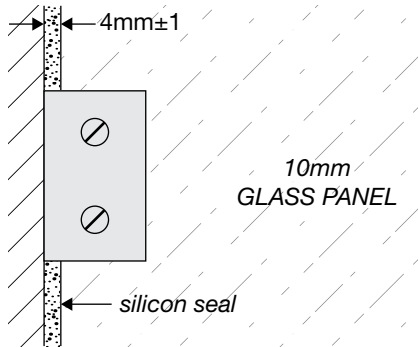

2/ CHANNEL

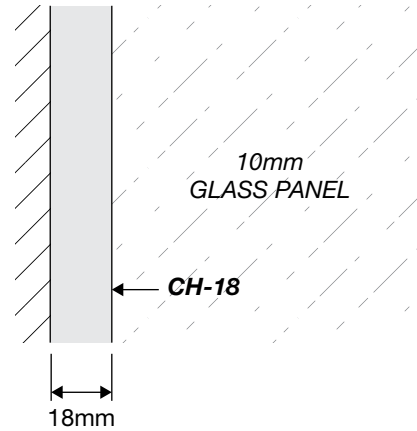

3/ REBATED CHANNEL (INTO TILES)

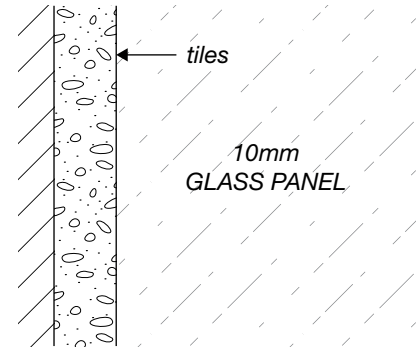

4/ GLASS-TO-FLOOR SEAL

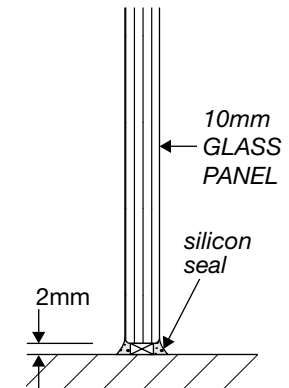
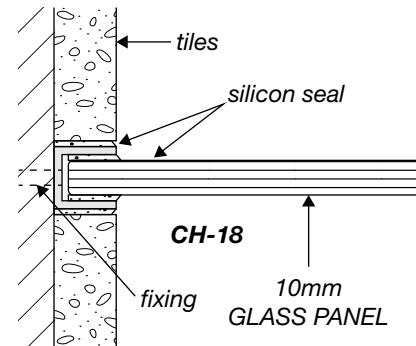
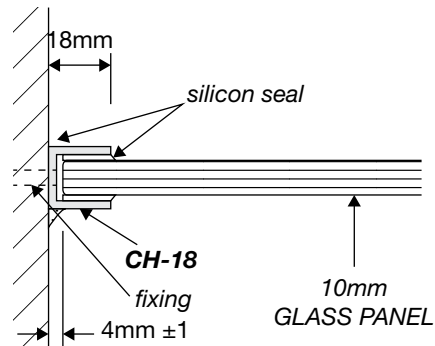
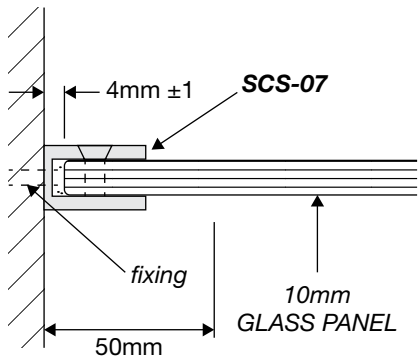
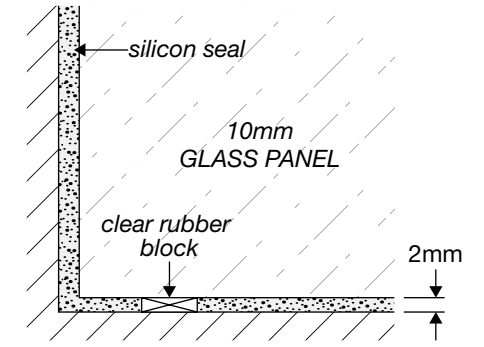

WALL MOUNT DRAWINGS

CLEAR WATER SEAL APPLICATIONS

OPTION 1

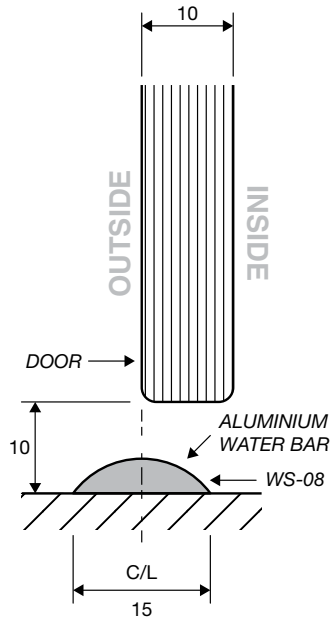

OPTION 2 (FIXED PANEL TO DOOR)

